

	*Kalk. skok widelca	Reach (mm)	Stack (mm)	ST (mm)	TT (mm)	eTT (mm)	CS (mm)	HT (mm)	HT kąt	eST kąt	BB drop (mm)	WB (mm)	**Stand-over (mm)	Rozmiar kół	Max rozmiar opon	***Skok widelca (mm)	Rozmiar płyty (mm)	Typ sterów (S.H.I.S)	Typ suportu (mm)	Śred. sztycy (mm)	Śred. objęmy (mm)	Mocowanie hamulca
<b>ROOTS L</b>	200	430	592	410	558	590	430	115	64°	75°	-5	1200	-	27.5"/26"	27.5"x2.5"	180-200	150x12	IS42/IS52	Euro 73	31.6	34.9	PM 160mm
<b>ROOTS S</b>	200	400	592	410	520	560	430	115	64°	75°	-5	1170	-	27.5"/26"	27.5"x2.5"	180-200	150x12	IS42/IS52	Euro 73	31.6	34.9	PM 160mm
<b>WISH L</b>	170	440	584	431	565	582	419	115	65°	76°	-4	1180	-	27.5"/26"	27.5"x2.35"	160-180	135x12	IS42/IS52	Euro 73	31.6	34.9	PM 160mm
<b>WISH S</b>	170	410	584	406	535	552	419	115	65°	76°	-4	1150	-	27.5"/26"	27.5"x2.35"	160-180	135x12	IS42/IS52	Euro 73	31.6	34.9	PM 160mm
<b>WISH 2013</b>	160	403	576	343	559	556	425	115	66.5°	75°	12	1128	-	26"	26"x2.35"	160-180	135x10	EC34/ZS49 EC34/EC49	Euro 73	31.6	34.9	IS
<b>SHINE</b>	140	387	565	305	554	564	403	115	67.5°	-	16	1081	-	26"	26"x2.2"	100-140	135x10	EC34/ZS49 EC34/EC49	Euro 73	27.2	31.8	IS
<b>HORNET L</b>	160	430	620	457	596	621	426	115	65.5°	73°	28	1160	-	27.5"/26"	27.5"x2.4"	120-170	135x12	IS42/IS52	Euro 73	31.6	34.9	IS
<b>HORNET M</b>	160	400	620	406	576	590	426	115	65.5°	73°	28	1130	-	27.5"/26"	27.5"x2.4"	120-170	135x12	IS42/IS52	Euro 73	31.6	34.9	IS
<b>HORNET 4X</b>	100	415	570	355	574	589	400	115	68°	73°	28	1076	-	26"	26"x2.4"	80-130	135x12	IS42/IS52	Euro 73	31.6	34.9	IS
<b>PRIMAL L</b>	140	415	610	477	591	625	425	115	67°	71°	30	1125	803	27.5"/26"	27.5"x2.2" 26"x2.35"	120-160	135x10	IS42/IS52	Euro 73	31.6	34.9	IS
<b>PRIMAL M</b>	140	390	610	452	573	604	425	115	67°	71°	30	1105	792	27.5"/26"	27.5"x2.2" 26"x2.35"	120-160	135x10	IS42/IS52	Euro 73	31.6	34.9	IS
<b>PRIMAL S</b>	140	370	610	426	559	585	425	115	67°	71°	30	1085	780	27.5"/26"	27.5"x2.2" 26"x2.35"	120-160	135x10	IS42/IS52	Euro 73	31.6	34.9	IS
<b>PRIMAL 29 L</b>	140	420	600	483	582	620	437	115	68°	71°	49	1190	785	29"	29"x2.2"	100-140	135x10	IS42/IS52	Euro 73	31.6	34.9	IS
<b>PRIMAL 29 M</b>	140	390	600	432	559	590	437	115	68°	71°	49	1160	766	29"	29"x2.2"	100-140	135x10	IS42/IS52	Euro 73	31.6	34.9	IS
<b>TWO6PLAYER L</b>	100	414	564	310	574	-	385	115	69°	-	20	1070	-	26"	26"x2.35"	90-130	135x10	EC34/ZS49 EC34/EC49	Euro 73	27.2	31.8	IS
<b>TWO6PLAYER S</b>	100	385	564	310	545	-	385	115	69°	-	20	1040	-	26"	26"x2.35"	90-130	135x10	EC34/ZS49 EC34/EC49	Euro 73	27.2	31.8	IS
<b>TWO4PLAYER</b>	100	387	550	300	548	-	370	115	69°	-	5	1016	-	24"	24"x2.35"	80-120	135x10	EC34/ZS49 EC34/EC49	Euro 73	27.2	31.8	IS
<b>TWO4PLAYER 2013</b>	100	394	539	300	546	-	370	105	69°	-	3	1016	-	24"	24"x2.35"	70-100	135x10	EC34/EC34	Euro 68	27.2	31.8	IS
<b>CODY</b>	100	400	558	300	570	-	380	110	69°	-	15	1040	-	26"	26"x2.35"	80-110	135x10	IS42/IS42	Spanish 68	27.2	zinteg.	IS
<b>QUINNIE</b>	100	402	543	300	574	-	383	110	68.5°	-	0	1050	-	26"	26"x2.35"	80-110	135x10	IS42/IS42	Euro 68	27.2	zinteg.	IS
<b>GHETTO</b>	80	390	507	270	546	-	360	110	70°	-	-24	988	-	24"	24"x2.35"	sztywny 60-100	135x10	IS42/IS42	Spanish 68	27.2	zinteg.	piwoty
<b>FREAKY</b>	sztywny	418	510	255	555	-	365	110	72.5°	-	5	966	-	24"/26"	24"x2.1" 26"x2.1"	sztywny	110x14	IS42/IS42	Spanish 68	25.4	zinteg.	piwoty

\* skok widelca użyty do wyliczeń danych geometrii w tej tabeli (w mm)

\*\* standover dla ramy Primal wyliczony jest dla kół 27.5"

\*\*\* rekomendowany zakres skoku widelca (w mm)

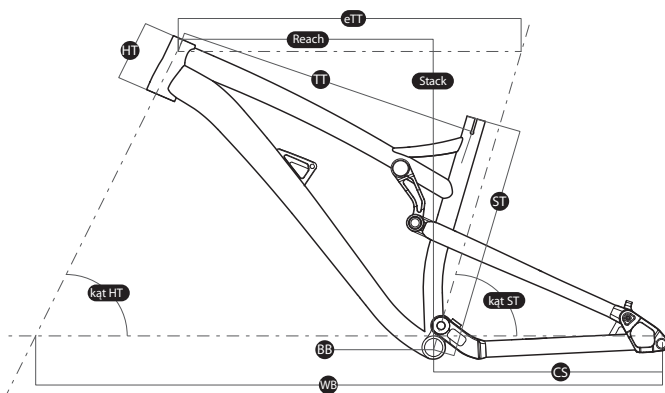

#### Objaśnienia używanych skrótów:

- TT** - długość górnej rury (rzeczywista)
- eTT** - długość górnej rury (efektywna)
- CS** - długość dolnych rurek tylnego trójkąta
- ST** - długość rury podsiodłowej (środek - góra)
- HT** - długość główki
- Reach** - odległość pomiędzy suportem a główką ramy w poziomie (środek - środek)
- Stack** - odległość pomiędzy suportem a główką ramy w pionie (środek - góra)
- WB** - baza kół
- BB drop** - położenie suportu w stosunku do linii bazy kół
- HT kąt** - kąt główki ramy
- ST kąt** - kąt rury podsiodłowej (efektywny)