

2022 HARDTAIL FRAMES GEOMETRY

	model	*calc. fork travel	reach (mm)	stack (mm)	ST (mm)	TT (mm)	eTT (mm)	CS (mm)	HT (mm)	HT angle (°)	eST angle (°)	BB drop	WB (mm)	stand-over (mm)	wheel size (")	max. tire size (")	max. chainring size	frame travel (mm)	shock size (mm)	shock hardware (mm)	**fork travel (mm)	hub size	headset type (S.H.I.S)	BB type (mm)	post diam. (mm)	clamp diam. (mm)	brake mount	max. rotor size (mm)
HORNET PRO																												
	MEDIUM	160	430	606	410	-	616	420	110	64	73	35	1174	756	27.5/Mullet	27.5x2.8	36T	-	-	-	140-180	148x12	IS42/IS60	BSA/Euro73	30.9	34.9	PM 160mm	203
	LARGE	160	460	606	440	-	645	420	110	64	73	35	1204	756	27.5/Mullet	27.5x2.8	36T	-	-	-	140-180	148x12	IS42/IS60	BSA/Euro73	30.9	34.9	PM 160mm	203
	XLARGE	160	480	606	455	-	665	420	110	64	73	35	1224	756	27.5/Mullet	27.5x2.8	36T	-	-	-	140-180	148x12	IS42/IS60	BSA/Euro73	30.9	34.9	PM 160mm	203
HORNET																												
	SMALL	160	405	625	380	-	596	425	120	64	73	35	1158	805	27.5/Mullet	27.5x2.8	36T	-	-	-	140-180	148x12	IS42/IS52	BSA/Euro73	30.9	34.9	PM 160mm	203
	MEDIUM	160	430	625	410	-	620	425	120	64	73	35	1183	805	27.5/Mullet	27.5x2.8	36T	-	-	-	140-180	148x12	IS42/IS52	BSA/Euro73	30.9	34.9	PM 160mm	203
	LARGE	160	460	625	440	-	650	425	120	64	73	35	1213	805	27.5/Mullet	27.5x2.8	36T	-	-	-	140-180	148x12	IS42/IS52	BSA/Euro73	30.9	34.9	PM 160mm	203
	XLARGE	160	480	625	455	-	672	425	120	64	73	35	1233	805	27.5/Mullet	27.5x2.8	36T	-	-	-	140-180	148x12	IS42/IS52	BSA/Euro73	30.9	34.9	PM 160mm	203
HORNET JR																												
	ONE SIZE	100	360	527	305	-	521	390	90	68	73	30	993	700	24	24x2.5	34T	-	-	-	100-140	135x10	IS42/IS52	BSA/Euro73	30.9	34.9	IS	160
HORNET 26																												
	ONE SIZE	140	420	565	330	-	603	400	100	68	70	30	1078	-	26	26x2.4	34T	-	-	-	100-160	148x12	IS42/IS52	BSA/Euro73	30.9	34.9	IS	180
PRIMAL 29																												
	SMALL	140	420	652	390	-	604	432	110	65	74	62	1165	790	29	29x2.4	34T	-	-	-	130-160	148x12	IS42/IS52	BSA/Euro73	30.9	34.9	PM 180mm	180
	MEDIUM	140	445	652	435	-	632	432	120	65	74	62	1194	790	29	29x2.4	34T	-	-	-	130-160	148x12	IS42/IS52	BSA/Euro73	30.9	34.9	PM 180mm	180
	LARGE	140	470	652	465	-	657	432	120	65	74	62	1219	800	29	29x2.4	34T	-	-	-	130-160	148x12	IS42/IS52	BSA/Euro73	30.9	34.9	PM 180mm	180
	XLARGE	140	495	652	465	-	685	432	130	65	74	62	1248	800	29	29x2.4	34T	-	-	-	130-160	148x12	IS42/IS52	BSA/Euro73	30.9	34.9	PM 180mm	180
PRIMAL 27.5																												
	SMALL	140	415	622	410	-	589	418	110	65	74	47	1134	774	27.5	27.5x2.6	34T	-	-	-	130-160	148x12	IS42/IS52	BSA/Euro73	30.9	34.9	PM 180mm	180
	MEDIUM	140	445	622	430	-	621	418	120	65	74	47	1169	774	27.5	27.5x2.6	34T	-	-	-	130-160	148x12	IS42/IS52	BSA/Euro73	30.9	34.9	PM 180mm	180
	LARGE	140	470	622	460	-	646	418	120	65	74	47	1194	781	27.5	27.5x2.6	34T	-	-	-	130-160	148x12	IS42/IS52	BSA/Euro73	30.9	34.9	PM 180mm	180
	XLARGE	140	495	622	460	-	675	418	130	65	74	47	1223	781	27.5	27.5x2.6	34T	-	-	-	130-160	148x12	IS42/IS52	BSA/Euro73	30.9	34.9	PM 180mm	180
PRIMAL 29 2021																												
	SMALL	140	410	636	435	-	600	432	100	66	73.5	62	1149	790	29	29x2.4	34T	-	-	-	130-160	148x12	IS42/IS52	BSA/Euro73	30.9	34.9	IS	180
	MEDIUM	140	430	636	455	-	620	432	100	66	73.5	62	1169	790	29	29x2.4	34T	-	-	-	130-160	148x12	IS42/IS52	BSA/Euro73	30.9	34.9	IS	180
	LARGE	140	450	636	475	-	640	432	100	66	73.5	62	1189	790	29	29x2.4	34T	-	-	-	130-160	148x12	IS42/IS52	BSA/Euro73	30.9	34.9	IS	180
	XLARGE	140	470	636	495	-	660	432	100	66	73.5	62	1209	790	29	29x2.4	34T	-	-	-	130-160	148x12	IS42/IS52	BSA/Euro73	30.9	34.9	IS	180
PRIMAL 27.5 2021																												
	SMALL	140	410	617	435	-	593	420	115	65.5	73.5	47	1145	790	27.5	27.5x2.6	34T	-	-	-	130-160	148x12	IS42/IS52	BSA/Euro73	30.9	34.9	IS	180
	MEDIUM	140	430	617	455	-	613	420	115	65.5	73.5	47	1165	790	27.5	27.5x2.6	34T	-	-	-	130-160	148x12	IS42/IS52	BSA/Euro73	30.9	34.9	IS	180
	LARGE	140	450	617	475	-	633	420	115	65.5	73.5	47	1185	790	27.5	27.5x2.6	34T	-	-	-	130-160	148x12	IS42/IS52	BSA/Euro73	30.9	34.9	IS	180
	XLARGE	140	470	617	495	-	653	420	115	65.5	73.5	47	1205	790	27.5	27.5x2.6	34T	-	-	-	130-160	148x12	IS42/IS52	BSA/Euro73	30.9	34.9	IS	180
STREETFIGHTER																												
	ONE SIZE	100	425	560	335	-	570	400	100	70	75	25	1066	-	26	26x2.5	32T	-	-	-	100-150	135x10	IS42/IS52	BSA/Euro73	30.9	34.9	IS	180
TWO6PLAYER PRO PIKE/BOMBER																												
	MEDIUM	100	410	571	337	552	-	385	120	69	74	25	1052	-	26	26x2.35	32T	-	-	-	90-130	135x10	IS42/IS52	BSA/Euro73	30.9	34.9	IS	160
	LONG	100	430	571	337	570	-	385	120	69	74	25	1072	-	26	26x2.35	32T	-	-	-	90-130	135x10	IS42/IS52	BSA/Euro73	30.9	34.9	IS	160
TWO6PLAYER																												
	SHORT	100	400	573	337	556	-	385	120	69	74	25	1043	-	26	26x2.35	32T	-	-	-	90-130	135x10	IS42/IS52	BSA/Euro73	30.9	34.9	IS	160
	LONG	100	425	573	337	577	-	385	120	69	74	25	1068	-	26	26x2.35	32T	-	-	-	90-130	135x10	IS42/IS52	BSA/Euro73	30.9	34.9	IS	160
TWO6PLAYER PUMP																												
	MEDIUM	100	410	573	337	565	-	385	120	69	74	25	1053	-	26	26x2.35	32T	-	-	-	90-130	135x10	IS42/IS52	BSA/Euro73	30.9	34.9	IS	160
CODY TAPERED																												
	ONE SIZE	100	400	558	300	570	-	380	110	69	-	15	1040	-	26	26x2.35	-	-	-	-	80-110	135x10	IS42/EC44	Spanish 68	27.2	integr.	IS	140
QUINNIE TAPERED																												
	ONE SIZE	100	412	558	300	576	-	383	110	69	-	15	1054	-	26	26x2.35	-	-	-	-	80-110	135x10	IS42/IS52	Euro 68	27.2	integr.	IS	160

* fork travel used for calculating the geometry showed in this table (in millimeters) ** recommended fork travel range (in millimeters)

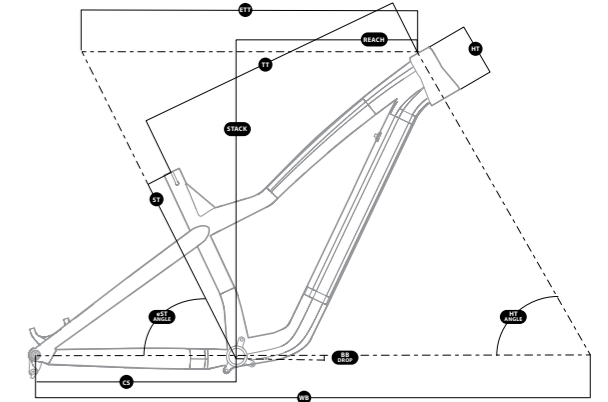

- reach** – horizontal distance from BB center to HT center
- stack** – vertical distance from BB center to HT top
- ST** – seat tube length (BB center to ST top)
- TT** – top tube length (actual)
- eTT** – top tube length (effective)
- CS** – chain stay length
- HT** – head tube length
- HT angle** – head tube angle
- eST angle** – effective seat tube angle
- BB drop** – bottom bracket height (BB center to WB)
- WB** – wheel base
- standover** – vertical distance from the ground to TT top (in the middle of the TT length with wheels assembled)

#RIDEYOURWAY