

model	*calc. fork travel	reach (mm)	stack (mm)	ST (mm)	TT (mm)	eTT (mm)	CS (mm)	HT (mm)	HT angle	ST angle	BB drop	WB (mm)	stand-over (mm)	wheel size	max. tire size (")	frame travel (mm)	shock size (mm)	shock hardware (mm)	**fork travel (mm)	hub size	headset type (S.H.I.S)	BB type (mm)	post diam. (mm)	clamp diam. (mm)	brake mount	max. rotor size (mm)	front derailleur compat.	weight (kg)
BLACKBIRD																												
SMALL	160	400	606	405	545	552	425	120	65°	76°	14	1147	790	27.5"	27.5x2.5	160	216x63	22.2x8	160-170	142x12	IS42/IS52	Euro73	30.9	34.9	PM 160mm	180	no	3.2
MEDIUM	160	435	606	430	577	587	425	120	65°	76°	14	1182	790	27.5"	27.5x2.5	160	216x63	22.2x8	160-170	142x12	IS42/IS52	Euro73	30.9	34.9	PM 160mm	180	no	(without shock);
LARGE	160	460	606	455	598	612	425	120	65°	76°	14	1207	790	27.5"	27.5x2.5	160	216x63	22.2x8	160-170	142x12	IS42/IS52	Euro73	30.9	34.9	PM 160mm	180	no	3.55
XLARGE	160	485	606	480	620	637	425	120	65°	76°	14	1232	790	27.5"	27.5x2.5	160	216x63	22.2x8	160-170	142x12	IS42/IS52	Euro73	30.9	34.9	PM 160mm	180	no	(with RS Monarch Plus RC3 HV shock)
BLUEBIRD																												
SMALL	130	400	606	400	530	525	430	110	66.5°	78°	30	1128	805	27.5"/29"	27.5x3.0 / 29x2.3	130	190x51	22.2x8	130-150	148x12	IS42/IS52	Euro73	30.9	34.9	IS	180	no	3.0 (without shock);
MEDIUM	130	435	606	450	555	557	430	110	66.5°	78°	30	1163	805	27.5"/29"	27.5x3.0 / 29x2.3	130	190x51	22.2x8	130-150	148x12	IS42/IS52	Euro73	30.9	34.9	IS	180	no	3.2 (w/RS Monarch RL shock)
LARGE	130	460	606	475	585	582	430	110	66.5°	78°	30	1188	805	27.5"/29"	27.5x3.0 / 29x2.3	130	190x51	22.2x8	130-150	148x12	IS42/IS52	Euro73	30.9	34.9	IS	180	no	
BLACKBIRD JR																												
	130	365	558	360	492	502	425	100	66°	73°	14	1075	750	26"	26x2.4	130	165x38	22.2x8	130-140	142x12	IS42/IS52	Euro73	30.9	34.9	PM 160mm	180	no	3.05 (without shock)
ROOTS																												
SHORT	200	400	592	410	520	560	430	115	64°	75°	-5	1170	-	27.5"/26"	27.5x2.5 / 26x2.5	200	222x69	22.2x8	180-200	150x12	IS42/IS52	Euro73	31.6	34.9	PM 160mm	203	no	3.34 (without shock)
LONG	200	430	592	410	558	590	430	115	64°	75°	-5	1200	-	27.5"/26"	27.5x2.5 / 26x2.5	200	222x69	22.2x8	180-200	150x12	IS42/IS52	Euro73	31.6	34.9	PM 160mm	203	no	3.41 (without shock)
WISH																												
SHORT	170	410	584	406	535	552	419	115	65°	76°	-4	1150	-	27.5"/26"	27.5x2.35 / 26x2.35	170	215x63	22.2x8	160-180	135x12	IS42/IS52	Euro73	31.6	34.9	PM 160mm	203	no	3.29 (without shock)
LONG	170	440	584	431	565	582	419	115	65°	76°	-4	1180	-	27.5"/26"	27.5x2.35 / 26x2.35	170	215x63	22.2x8	160-180	135x12	IS42/IS52	Euro73	31.6	34.9	PM 160mm	203	no	3.35 (without shock)
HORNET																												
SMALL	160	405	620	380	585	595	425	120	65°	73°	30	1151	805	27.5"	27.5x2.8	-	-	-	140-180	142x12	IS42/IS52	Euro73	30.9	34.9	PM 160mm	203	no	2.6
MEDIUM	160	430	620	410	603	620	425	120	65°	73°	30	1176	805	27.5"	27.5x2.8	-	-	-	140-180	142x12	IS42/IS52	Euro73	30.9	34.9	PM 160mm	203	no	2.65
LARGE	160	450	620	440	626	650	425	120	65°	73°	30	1206	805	27.5"	27.5x2.8	-	-	-	140-180	142x12	IS42/IS52	Euro73	30.9	34.9	PM 160mm	203	no	2.70
HORNET 4X																												
	100	415	570	355	574	589	400	115	68°	73°	28	1076	-	26"	26x2.4	-	-	-	80-130	135x12	IS42/IS52	Euro73	30.9	34.9	IS	160	no	2.15
HORNET JUNIOR																												
	100	360	527	305	514	521	390	90	68°	73°	30	993	700	24"	24x2.5	-	-	-	100-140	135x10	IS42/IS52	Euro73	30.9	34.9	IS	160	no	1.90
PRIMAL 27.5																												
SMALL	140	410	617	435	584	593	420	115	65.5°	73.5°	47	1145	790	27.5"	27.5x2.8	-	-	-	130-160	148x12	IS42/IS52	Euro73	30.9	34.9	IS	180	no	
MEDIUM	140	430	617	455	602	613	420	115	65.5°	73.5°	47	1165	790	27.5"	27.5x2.8	-	-	-	130-160	148x12	IS42/IS52	Euro73	30.9	34.9	IS	180	no	
LARGE	140	450	617	475	619	633	420	115	65.5°	73.5°	47	1185	790	27.5"	27.5x2.8	-	-	-	130-160	148x12	IS42/IS52	Euro73	30.9	34.9	IS	180	no	2.25
X-LARGE	140	470	617	495	637	653	420	115	65.5°	73.5°	47	1205	790	27.5"	27.5x2.8	-	-	-	130-160	148x12	IS42/IS52	Euro73	30.9	34.9	IS	180	no	
PRIMAL 29																												
SMALL	140	410	636	435	593	600	430	100	66°	73.5°	62	1150	790	29"	29x2.35	-	-	-	130-160	148x12	IS42/IS52	Euro73	30.9	34.9	IS	180	no	
MEDIUM	140	430	636	455	615	620	430	100	66°	73.5°	62	1170	790	29"	29x2.35	-	-	-	130-160	148x12	IS42/IS52	Euro73	30.9	34.9	IS	180	no	
LARGE	140	450	636	475	629	640	430	100	66°	73.5°	62	1190	790	29"	29x2.35	-	-	-	130-160	148x12	IS42/IS52	Euro73	30.9	34.9	IS	180	no	2.30
XLARGE	140	470	636	495	647	660	430	100	66°	73.5°	62	1210	790	29"	29x2.35	-	-	-	130-160	148x12	IS42/IS52	Euro73	30.9	34.9	IS	180	no	
TWO6PLAYER																												
SHORT	100	400	550	337	556	-	385	120	69°	74°	25	1048	-	26"	26"x2.35"	-	-	-	90-130	135x10	IS42/IS52	Euro73	30.9	34.9	IS	160	no	2.20
LONG	100	425	550	337	577	-	385	120	69°	74°	25	1063	-	26"	26"x2.35"	-	-	-	90-130	135x10	IS42/IS52	Euro73	30.9	34.9	IS	160	no	2.25
TWO4PLAYER																												
	100	387	550	300	548	-	370	115	69°	-	5	1016	-	24"	24"x2.35"	-	-	-	80-120	135x10	EC34/ZS49 EC34/EC49	Euro73	27.2	31.8	IS	160	no	2.10
CODY																												
	100	400	558	300	570	-	380	110	69°	-	15	1040	-	26"	26"x2.35"	-	-	-	80-110	135x10	IS42/IS42	Spanish 68	27.2	integr.	IS	140	no	2.26
CODY TAPERED																												
	100	400	558	300	570	-	380	110	69°	-	15	1040	-	26"	26"x2.35"	-	-	-	80-110	135x10	IS42/EC44	Spanish 68	27.2	integr.	IS	140	no	2.26
QUINNIE																												
	100	402	543	300	574	-	383	110	68.5°	-	0	1050	-	26"	26"x2.35"	-	-	-	80-110	135x10	IS42/IS42	Euro 68	27.2	integr.	IS	160	no	2.48
FREAKY																												
	rigid	418	510	255	555	-	365	110	72.5°	-	5	966	-	24"/26"	24"x2.1" 26"x2.1"	-	-	-	rigid	110x14	IS42/IS42	Spanish 68	25.4	integr.	pivots	-	no	2.44

* fork travel used for calculating the geometry showed in this table (in millimetres) ** recommended fork travel range (in millimetres)

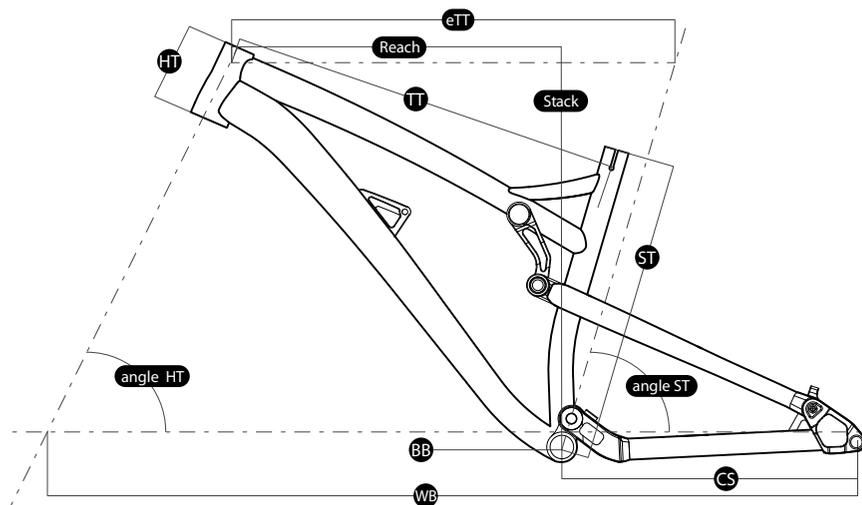

- reach** – horizontal distance from BB center to HT center
- stack** – vertical distance from BB center to HT top
- ST** – seat tube length (BB center to ST top)
- TT** – top tube length (actual)
- eTT** – top tube length (effective)
- CS** – chain stay length
- HT** – head tube length
- HT angle** – head tube angle
- ST angle** – seat tube angle
- BB drop** – bottom bracket height (BB center to WB)
- WB** – wheel base
- standover** – vertical distance from the ground to TT top (in the middle of the TT length with wheels assembled)