

	reach (mm)	stack (mm)	ST (mm)	TT (mm)	eTT (mm)	CS (mm)	HT (mm)	HT angle	ST angle	BB drop (mm)	WB (mm)	stand- over (mm)	wheel size	hub size	headset type (S.H.I.S.)	BB type (mm)	post diam. (mm)	clamp diam. (mm)	brake mount	max. rotor size (mm)
ROOTS RED DEVIL S	400	592	410	520	560	430	115	64°	75°	-5	1170	-	27.5"	150x12	IS42/IS52	Euro73	31.6	34.9	PM 160mm	203
ROOTS RED DEVIL L	430	592	410	558	590	430	115	64°	75°	-5	1200	-	27.5"	150x12	IS42/IS52	Euro73	31.6	34.9	PM 160mm	203
ROOTS BLACK ANGEL S	400	592	410	520	560	430	115	64°	75°	-5	1170	-	27.5"	150x12	IS42/IS52	Euro73	31.6	34.9	PM 160mm	203
ROOTS BLACK ANGEL L	430	592	410	558	590	430	115	64°	75°	-5	1200	-	27.5"	150x12	IS42/IS52	Euro73	31.6	34.9	PM 160mm	203
ROOTS GREY ANGEL S	400	592	410	520	560	430	115	64°	75°	-5	1170	-	26"	150x12	IS42/IS52	Euro73	31.6	34.9	PM 160mm	203
ROOTS GREY ANGEL L	430	592	410	558	590	430	115	64°	75°	-5	1200	-	26"	150x12	IS42/IS52	Euro73	31.6	34.9	PM 160mm	203
WISH ENDURO S	410	584	406	535	552	419	115	65°	76°	-4	1150	-	27.5"	135x12	IS42/IS52	Euro73	31.6	34.9	PM 160mm	203
WISH ENDURO L	440	584	431	565	582	419	115	65°	76°	-4	1180	-	27.5"	135x12	IS42/IS52	Euro73	31.6	34.9	PM 160mm	203
WISH BIKEPARK S	410	584	406	535	552	419	115	65°	76°	-4	1150	-	26"	135x12	IS42/IS52	Euro73	31.6	34.9	PM 160mm	203
WISH BIKEPARK L	440	584	431	565	582	419	115	65°	76°	-4	1180	-	26"	135x12	IS42/IS52	Euro73	31.6	34.9	PM 160mm	203
HORNET M	400	620	406	576	590	426	115	66.5°	73°	28	1130	-	27.5"	135x12	IS42/IS52	Euro73	31.6	34.9	IS	203
HORNET L	430	620	457	596	621	426	115	66.5°	73°	28	1160	-	27.5"	135x12	IS42/IS52	Euro73	31.6	34.9	IS	203
PRIMAL PRO S	373	610	426	559	585	425	115	67°	71°	30	1085	780	27.5"	135x10	IS42/IS52	Euro73	31.6	34.9	IS	180
PRIMAL PRO M	393	610	452	573	604	425	115	67°	71°	30	1105	792	27.5"	135x10	IS42/IS52	Euro73	31.6	34.9	IS	180
PRIMAL PRO L	413	610	477	591	625	425	115	67°	71°	30	1125	803	27.5"	135x10	IS42/IS52	Euro73	31.6	34.9	IS	180
PRIMAL BASIC S	382	603	426	559	580	425	115	68°	72°	38	1085	780	27.5"	135x10	IS42/IS52	Euro73	31.6	34.9	IS	180
PRIMAL BASIC M	402	603	452	573	600	425	115	68°	72°	38	1105	792	27.5"	135x10	IS42/IS52	Euro73	31.6	34.9	IS	180
PRIMAL BASIC L	422	603	477	591	620	425	115	68°	72°	38	1125	803	27.5"	135x10	IS42/IS52	Euro73	31.6	34.9	IS	180
TWOGPLAYER PRO	414	564	310	574	-	385	115	69°	-	20	1070	-	26"	135x10	EC34/EC49	Euro73	27.2	31.8	IS	160
TWOGPLAYER	414	564	310	574	-	385	115	69°	-	20	1070	-	26"	135x10	EC34/EC49	Euro73	27.2	31.8	IS	160
QUINNIE	402	543	300	574	-	383	110	68.5°	-	0	1050	-	26"	135x10	IS42/IS42	Spanish68	27.2	integr.	IS	160
GAMER26	403	579	354	557	-	385	115	70°	-	25	1036	-	26"	135x10	IS42/IS52	Euro73	27.2	31.8	IS	160
GAMER26 BASIC	403	579	354	557	-	385	115	70°	-	25	1036	-	26"	135x10	IS42/IS52	Euro73	27.2	31.8	IS	160
GAMER24 BASIC	388	562	325	540	-	370	115	70°	-	8	1006	-	24"	135x10	IS42/IS52	Euro68	27.2	31.8	IS	160

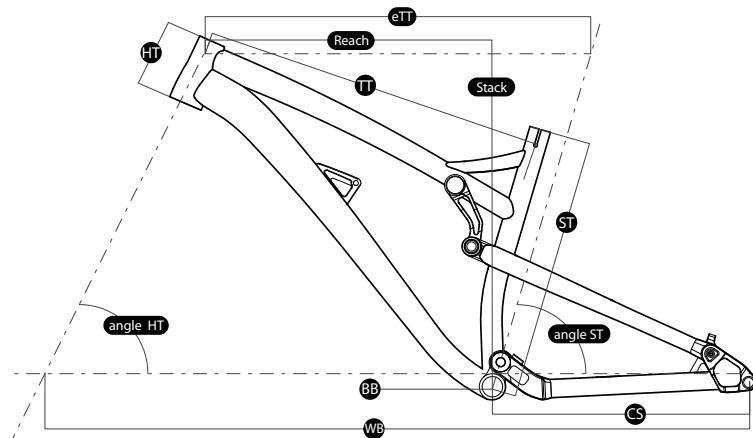

- reach** – horizontal distance from BB center to HT center
- stack** – vertical distance from BB center to HT top
- ST** – seat tube length (BB center to ST top)
- TT** – top tube length (actual)
- eTT** – top tube length (effective)
- CS** – chain stay length
- HT** – head tube length
- HT angle** – head tube angle
- eST angle** – seat tube angle (effective)
- BB drop** – bottom bracket height (BB center to WB)
- WB** – wheel base
- standover** – vertical distance from the ground to TT top (in the middle of the TT length with wheels assembled)